

**Канатный электротельфер Т10 Передвигаемый одной тележкой, полиспаст 2/1**

- (1) с микроподъемом
- (2) с ограничителем груза
- (3) с ограничителем груза и с микроподъемом

Тип	Полиспаст 2/1		Размеры, mm																						
	Высота подъема, m	Грузоподъемность, kg	Скорость подъема m/min				L2	L3	L4	L5	L6	L7	H1	H2	H3	B	B1	B2	B3	B4	B5	e	C	D	
			8	12	8/2	12/2																			
			L1																						
T102...	H1	6	500	648	688	287	225	60	68	415	46	148	204	33	90... 130	465 492 <sup>(1)</sup> 557 <sup>(3)</sup>	300 365 <sup>(2)</sup>	94... 54	245... 305	34	18	850	120		
	H2	9		738	778	332																		80	88
	H3	12		818	858	373																		80	88
T103...	H1	6	1000	709	749	310	225	75	82	415	70	148	204	33	90... 130	465 492 <sup>(1)</sup> 557 <sup>(3)</sup>	300 365 <sup>(2)</sup>	94... 54	245... 305	40	18	910	120		
	H2	9		814	854	362																		100	106
	H3	12		914	954	412																		100	106
T104...	H1	6	2000	816	880	362	280	73	79	536	80	200	272	42	130... 150	580 606 <sup>(1)</sup> 668 <sup>(3)</sup>	380 442 <sup>(2)</sup>	125... 105	270... 335	45	22	1120	175		
	H2	9		926	990	417																		96	104
	H3	12		1026	1090	467																		96	104
T105...	H1	6	3200	856	923	377	280	82	89	536	80	200	272	42	130... 150	580 606 <sup>(1)</sup> 668 <sup>(3)</sup>	380 442 <sup>(2)</sup>	125... 105	270... 335	50	22	1200	175		
	H2	9		976	1043	437																		110	116
	H3	12		1086	1153	492																		110	116
T106...	H1	6	5000	905	993	395	310	75	82	595	90	232	317	33	130... 150	675 682 <sup>(1)</sup> 760 <sup>(3)</sup>	430 508 <sup>(2)</sup>	145... 125	300... 365	56	26	1380	210		
	H2	9		1010	1098	448																		101	108
	H3	12		1115	1203	500																		101	108

Тип	Полиспаст 2/1		Скорость подъема, m/min			
	Высота подъема, m	Грузоподъемность, kg	8	12	8/2	12/2
			Вес, kg			
T102...	H1	6	500	129		147
	H2	9		135		153
	H3	12		138		156
T103...	H1	6	1000	137		160
	H2	9		142		165
	H3	12		152		175
T104...	H1	6	2000	290		337
	H2	9		305		352
	H3	12		315		362
T105...	H1	6	3200	325	335	390
	H2	9		340	350	405
	H3	12		355	365	420
T106...	H1	6	5000	488		583
	H2	9		508		603
	H3	12		528		623

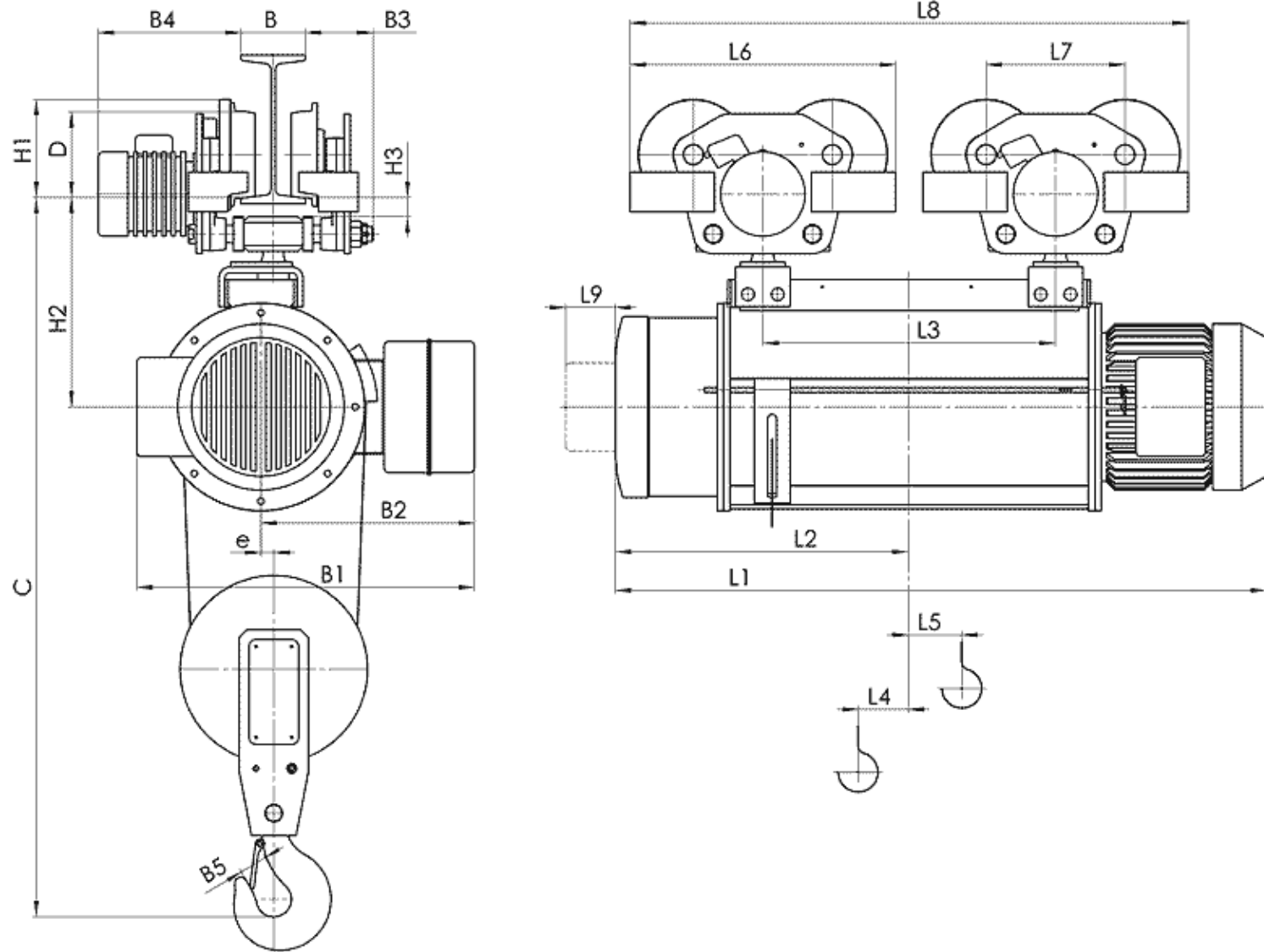

**Канатный электротельфер Т10 Передвигаемый двумя тележками, полиспаст 2/1**

- (1) с микроподъемом
- (2) с ограничителем груза
- (3) с ограничителем груза и с микроподъемом

Полиспагст 2/1			Размеры, mm																											
Тип	Высота подъема, m		Грузоподъемность, kg		подъема		L2	L3	L4	L5	L6	L7	L8	L9	H1	H2	H3	B	B1	B2	B3	B4	B5	e	C	D				
					8	12																					8/2	12/2		
					L1																									
					Скорость																									
T102...	H4	18	500	978	1018	452	450	55	192	415	225	865	46	148	277	33	90...	110	465	492 <sup>(1)</sup>	300	365 <sup>(2)</sup>	94...	245...	34	18	930	120		
	H5	24		1138	1178	532	610	55	272																				965	
	H6	30		1226	1290	567	550	89	214																					1035
	H7	36		1306	1373	602	620	110	228																					
T103...	H4	18	1000	1114	1154	512	570	75	231	415	225	985	70	200	277	33	90...	110	465	492 <sup>(1)</sup>	300	365 <sup>(2)</sup>	94...	245...	40	18	995	120		
	H5	24		1314	1354	612	770	149	332																				1165	
	H6	30		1426	1490	667	750	90	312																					1255
	H7	36		1526	1593	712	840	110	338																					
T104...	H4	18	2000	1226	1290	567	550	90	212	536	280	1086	80	200	368	37	130...	150	580	606 <sup>(1)</sup>	380	442 <sup>(2)</sup>	125...	270...	45	22	1225	175		
	H5	24		1426	1490	667	750	90	312																				1336	
	H6	30		1535	1623	710	800	88	346																					1441
	H7	36		1640	1728	762	905	75	398																					
T105...	H4	18	3200	1306	1373	602	620	110	226	536	280	1156	80	200	360	37	130...	150	580	606 <sup>(1)</sup>	380	442 <sup>(2)</sup>	125...	270...	50	22	1310	175		
	H5	24		1526	1593	712	840	110	336																				1441	
	H6	30		1640	1728	762	905	75	398																					1616
	H7	36		1815	1903	850	1080	75	436																					
T106...	H4	18	5000	1325	1413	605	590	124	193	536	280	1146	90	200	410	37	130...	150	675	682 <sup>(1)</sup>	430	508 <sup>(2)</sup>	125...	270...	56	26	1575	175		
	H5	24		1535	1623	710	800	124	296																				1616	
	H6	30		1815	1903	850	1080	124	399																					1631
	H7	36		1963	1969	905	1095	99	462																					

T107...	H2	9	8000	1133	1168	507	630	77	82	595	310	1225	100	230	540	30	130...	765	470	145...	300...	71	38	1800	210
	H3	12		1293	1328	587	780	118	123			1375													
	H4	18		1453	1488	667	940	78	242			1535													
	H5	24		1668	1703	775	1155	78	350			1750													
	H6	30		1883	1918	882	1370	78	457			1965													
	H7	36		2093	2128	987	1580	78	562			2175													

Тип	Полиспаст 2/1		Скорость подъема m/min	L2	L3	L4	L5	L6	L7	L8	L9	H1	H2	H3	B	B1	B2	B3	B4	B5	e	C	D						
	Высота подъема, m	Грузоподъемность, kg																						16	16/2.5				
																								L1					
T102...	H6	30	500	1226	1290	567	550	89	214	415	225	965	80	148	331	33	90...	580	380	94...	245...	34	22	1025	120				
	H7	36		1306	1373	602	620	110	228			1035														606 <sup>(1)</sup>	442 <sup>(2)</sup>	54	305
T103...	H5	24	1000	1226	1290	567	610	90	212	415	225	1025	80	148	331	33	130...	580	380	94...	245...	40	22	1085	120				
	H6	30		1426	1490	667	750	90	312			1165														606 <sup>(1)</sup>	442 <sup>(2)</sup>	54	305
	H7	36		1526	1593	712	840	110	338			1255														668 <sup>(3)</sup>			
T104...	H5	24	2000	1325	1413	605	650	75	242	536	280	1186	90	200	410	37	130...	675	430	125...	270...	45	26	1300	175				
	H6	30		1535	1623	710	800	88	346			1336														682 <sup>(1)</sup>	508 <sup>(2)</sup>	105	335
	H7	36		1640	1728	762	905	75	398			1441														760 <sup>(3)</sup>			
T105...	H4	18	3200	1325	1413	605	650	75	242	536	280	1186	90	200	410	37	130...	675	430	125...	270...	50	26	1385	175				
	H5	24		1535	1623	710	860	75	347			1396														682 <sup>(1)</sup>	508 <sup>(2)</sup>	105	335
	H6	30		1640	1728	762	905	75	398			1441														760 <sup>(3)</sup>			
	H7	36		1815	1903	850	1080	75	436			1616																	
T106...	H4	18	5000	1488	1494	667	690	94	230	536	280	1226	100	200	540	37	130...	765	470	125...	270...	56	38	1600	175				
	H5	24		1588	1594	717	790	94	280			1326														845 <sup>(3)</sup>	550 <sup>(2)</sup>	105	335
	H6	30		1778	1784	812	960	94	330			1496																	
	H7	36		1963	1969	905	1095	99	462			1631																	
T107...	H2	9	8000	1133	1168	507	630	77	82	595	310	1225	100	230	540	30	130...	765	470	145...	300...	71	38	1800	210				
	H3	12		1293	1328	587	780	118	123			1375																	
	H4	18		1453	1488	667	940	78	242			1535																	
	H5	24		1668	1703	775	1155	78	350			1750																	
	H6	30		1883	1918	882	1370	78	457			1965																	
	H7	36		2093	2128	987	1580	78	562			2175																	

Тип	Полиспаст 2/1		Скорость подъема, m/min					
	Высота подъема, m	Грузопо- дъемность, kg	8	12	8/2	12/2	16	16/2.5
			Вес, kg					
Т102...	H4	18	500	119	137	226	272	
	H5	24		128	146	244	290	
	H6	30		250	297	251	297	
	H7	36		273	320	274	320	
Т103...	H4	18	1000	218	241	330	376	
	H5	24		232	255	347	393	
	H6	30		375	422	376	422	
	H7	36		395	442	396	442	
Т104...	H4	18	2000	459	506	664	719	
	H5	24		484	631	684	739	
	H6	30		691	786	731	786	
	H7	36		711	806	751	806	
Т105...	H4	18	3200	504	514	569	686	741
	H5	24		534	544	599	731	786
	H6	30		721	761	816	761	816
	H7	36		746	786	841	786	841
Т106...	H4	18	5000	656	751	998	1003	
	H5	24		706	801	1018	1023	
	H6	30		802	897	1038	1043	
	H7	36		1040	1100	1100	1105	
Т107...	H2	9	8000	988	1048	1048	1053	
	H3	12		1036	1096	1096	1101	
	H4	18		1108	1168	1168	1173	
	H5	24		1175	1235	1235	1240	
	H6	30		1244	1304	1304	1309	
	H7	36		1314	1374	1374	1379	