

Т 45... - 2/1 (уменьшенная строительная высота)

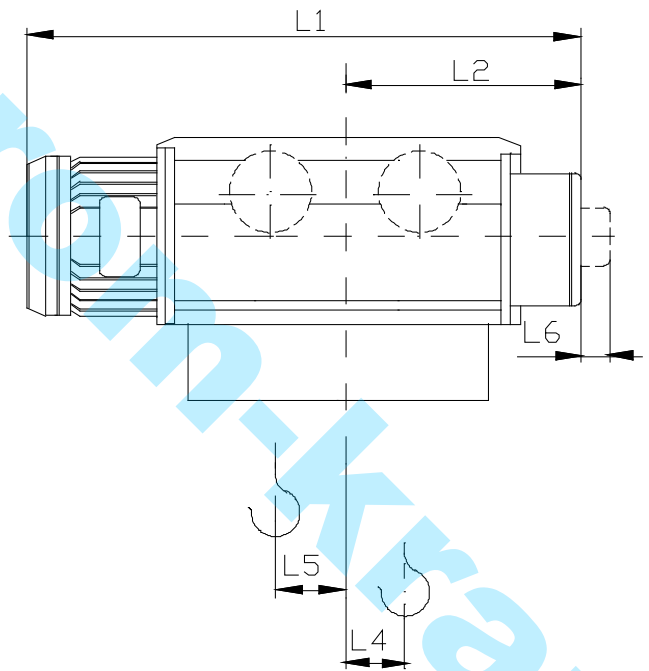
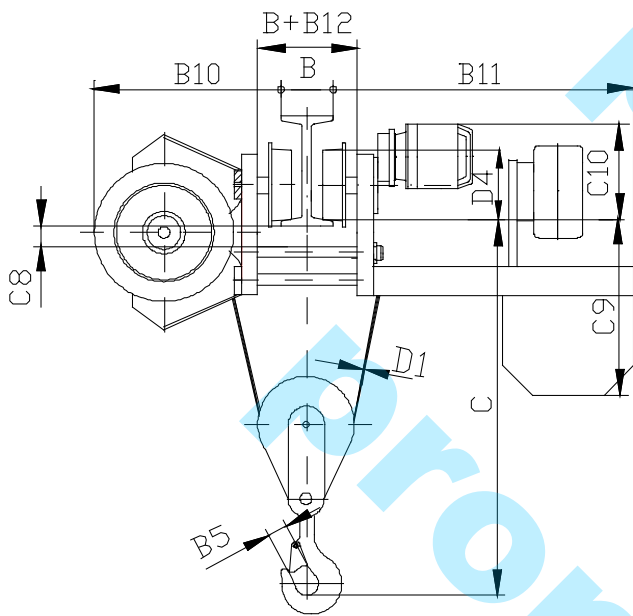

Размеры, мм

Г/п, тн.	Тип/ в/п, м	B5	B10	B11	B12	C	C8	C9	C10					D1	D4	Полиспаст 2/1				L2	L4	L5	L6	Масса				
									скорость перемещения, м/мин							L1								противовеса, кг				
									20 ¹⁾	20	8	12/4	32/10			T..	T..M	T2..	T2..M					T..	T..M	T2..	T2..M	
									32	10	15/5	12	20/6			15												
0,5 Т 452..	H1													640	680	640	680	280	37	32					34	45	34	45
	H2	34	370	550	104	465	19	390	206	204	238	257	223	6	120	730	770	730	770	325	82	32		75	38	47	38	47
	H3														810	850	810	850	365	122	32			42	50	42	50	
1,0 Т 453..	H1													705	745	705	745	300	54	38				75	45	53	45	53
	H2	40	370	550	114	525	19	390	206	204	238	257	223	8	120	810	850	810	850	355	106	38		75	48	61	48	61
	H3														910	950	910	950	405	156	38			52	68	52	68	
2,0 Т 454..	H1													805	870	805	870	355	48	43				83	57	75	57	75
	H2	45	480	675	126	725	22	490	245	252	290	290	252	11	175	915	980	915	980	410	103	43		83	58	76	58	76
	H3														1015	1080	1015	1080	460	153	43			59	77	59	77	
3,2 Т 455..	H1													850	935	880	935	370	53	54				83	73	101	75	101
	H2	50	480	675	126	725	22	490	245	252	290	290	252	13	175	970	1055	1000	1055	430	113	54		83	76	103	78	103
	H3														1080	1165	1110	1165	485	168	54			78	104	80	104	
5,0 Т 456..	H1													890	980	925	980	380	47	38				100	110	140	126	144
	H2	56	585	805	144	785	25	485	273	280	320	320	-	16	210	995	1085	1030	1085	430	99	38		100	113	145	131	148
	H3														1100	1190	1135	1190	485	152	38			117	148	135	151	

1) без тормоза перемещения